

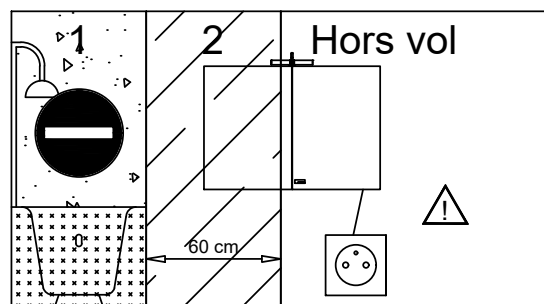

# 3014375

17/11/11-11- 04/10/2022

## BOX



- 
- (F) Cette notice est destinée à faciliter le montage du meuble, elle n'est pas contractuelle.
  - (GB) Fitting instructions are intended to ease fitting. They are not subject to contract.
  - (D) Unverbindliche Montageanleitung.
  - (NL) Deze montagehandleiding is bedoeld om de montage te vereenvoudigen. Zij is niet bindend.
  - (SP) Esta nota de instrucciones le ayudará a montar el mueble, no es contractual.
  - (I) Le seguenti istruzioni sono destinate a facilitarvi il montaggio del mobile, e sono indicative.
  - (P) Este folheto é destinado a facilitar a montagem do móvel, não é contratual.
  - (RUS) Настоящие инструкции помогут вам проще и быстрее собрать мебель. Производители в любое время может внести изменения в изделие для улучшения качества и усовершенствования дизайна.

- 
- (F) Le choix des types de vis et chevilles, ainsi que la méthode de perçage pour les fixations murales sont fonction de la nature et de la qualité du mur et, de ce fait, relèvent de la seule responsabilité du poseur.
  - (GB) Since the type of wall determines the fittings necessary for each unit, bolts and screws have not been supplied but left to the responsibility of the installer.
  - (D) Das Befestigungsmaterial (Schrauben und Dübel), muss je nach Beschaffenheit der Wand (Mauerwerk, Gipskarton etc.) ausgewählt werden. Die Verantwortung für die einwandfreie Installation, übernimmt der Fachmann.
  - (NL) Omdat de manier van bevestigen bepaald wordt door het type muur, zijn schroeven en pluggen niet inbegrepen en vallen onder de verantwoordelijkheid van de installateur.
  - (SP) La elección del tipo de los torillos y clavijos y el modo de perforar la pared dependen de la naturaleza y de la calidad del muro y por esto dependen de la responsabilidad de la persona quien instala.
  - (I) La scelta dei tipi di viti e tasselli, oltre che il sistema di foratura per il fissaggio murale sono da scegliere in funzione della struttura e qualità del muro, e per questo. La responsabilità spetta à chi esegue la posa.
  - (P) A escolha do tipos de parafusos e buchas assim como o metodo de furar para colocar as fixações murais depende da natureza e da qualidade do muro, e de facto, atribuem a unica responsabilidade ao instalador.
  - (RUS) Поскольку каждая стена имеет свои особенности крепеж для установки не поставляется. Специалист по сборке должен подобрать соответствующий тип креплений самостоятельно.

- 
- (F) Tous les raccordements électriques doivent être réalisés selon les réglementations en vigueur par une personne qualifiée.
  - (GB) All electrical connections must be made in accordance with the latest IEE regulations ( BS EN ) by a qualified person.
  - (D) Alle elektrischen Anschlüsse, müssen gemäß den VDE-Vorschriften, von einem Fachmann installiert werden.
  - (NL) Alle elektrische aansluiten dienen, conform de geldende normen, te worden geïnstalleerd door een erkend installateur
  - (SP) Todas las conexiones eléctricas deberán ser realizadas por personal cualificado y siguiendo las regulaciones marcadas por el IEE (Instituto de Ingenieros Eléctricos)
  - (I) Elettriche devono essere eseguite da personale qualificato e in conformità alle più recenti norme IEE (Institution of Electrical Engineers)
  - (P) Todas as instalações eléctricas devem ser realizadas segundo as regulamentações em vigor por uma pessoa qualificada.
  - (RUS) Все электрические соединения должны уст анавливаться квалифицированным п ерсоналом и соответствовать последним стандартам IEE (Институт Инженерном Электроники, Великобритания)

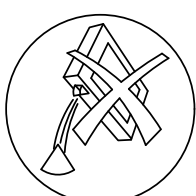
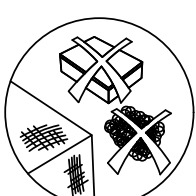
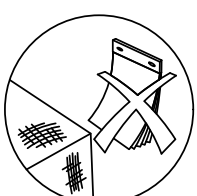
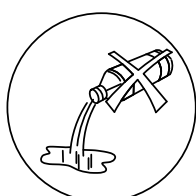
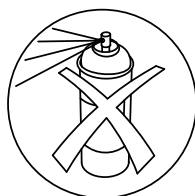

**Précaution** : couper le courant du circuit concerné ou de l'installation électrique lors du branchement de l'appareil.

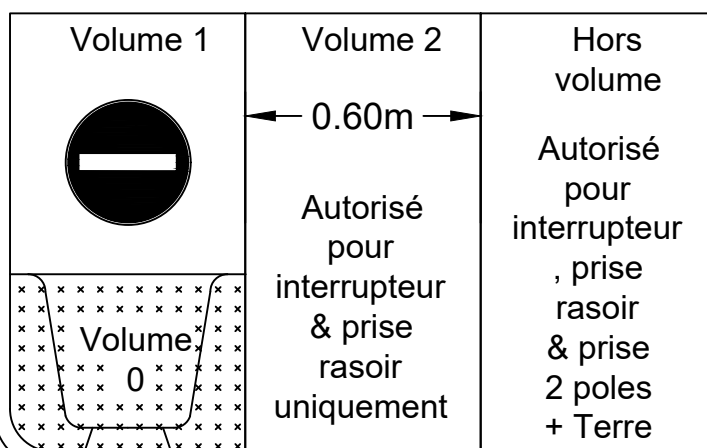

Cet appareil de classe II peut être installé dans le volume 2 de la salle de bain (Il est interdit au dessus de la baignoire ou dans le volume de la douche). Il peut être installé sans restriction dans toutes les autres pièces.



- (GB) Caution: switch off the main power before connecting. This class II device may be installed in bathroom (zone 2 or 3). Prohibited above bathtub or inside the shower area. It may be installed in any other room with no restrictions.
- (D) Vorsichtsmaßnahme : Vor Anschluss des Gerätes den betroffenen Stromkreis oder die Stromversorgung für die elektrische Installation abschalten. Dieses Gerät der Klasse II kann im Bereich 2 des Badezimmers installiert werden (die Montage über der Badewanne und im Bereich der Dusche ist verboten). In allen sonstigen Räumen kann das Gerät uneingeschränkt installiert werden.
- (NL) Opgelet: Bij het aansluiten van het apparaat dient de stroom van de betreffende stroombaan of van de elektrische installatie te worden afgesloten. Dit toestel van klasse II mag in volume 2 van de badkamer worden geplaatst (het is verboden boven het bad of in de doucheruimte). Het mag zonder beperkingen geïnstalleerd worden in alle andere kamers.
- (SP) Precaución: desconecte la alimentación eléctrica del circuito al conectar el dispositivo. Esta clase de aparatos II puede instalarse en el volumen 2 del cuarto de baño (está prohibido sobre la bañera o dentro del espacio de la ducha). Puede instalarse sin restricción en cualquier otra habitación.
- (P) Desligue a corrente elétrica antes de qualquer intervenção no circuito elétrico. Este aparelho de classe II pode ser instalado no volume 2 da casa de banho (é proibido por cima da banheira ou no volume do duche). Pode ser instalado sem restrições em todas os outros volumes.
- (RUS) Предупреждение: Отключите электроэнергию перед подключением. Устройство класса II можно установить в ванной комнате (зона 2 или 3). Запрещена установка над ванной или внутри душевого пространства. Устройство может быть установлено так же в другом помещении без ограничений.



- (F) Dans les locaux recevant une baignoire ou une douche et des prises de courant inférieures ou égal à 32A, le circuit électrique correspondant doit être protégé par un dispositif à courant différentiel résiduel (DDR) inférieur ou égal à 30 mA.
- (GB) In any room containing bathtub or shower area and plugs less or equal to 32A, the electrical circuit of this room must be under the controlled of a leak current protective switch calibrated up to 30mA.
- (D) In Räumen, die mit einer Badewanne oder Dusche und Steckdosen mit <32A ausgestattet sind, muss der entsprechende Stromkreis durch einen Differenzstrom-Schutzschalter <30 mA geschützt werden.
- (NL) In ruimtes met een bad of een douche en stopcontacten lager of gelijk aan 30A, moet de betreffende stroombaan beveiligd zijn door een differentieelschakelaar van maximaal 30 mA.
- (SP) Donde se coloque una bañera o una ducha y las salidas de corriente sean inferior o igual a 32A, el circuito eléctrico correspondiente debe estar protegido por un diferencial residual inferior o igual a 30mA.
- (P) Nos locais com banho ou ducha e que dispõem de alimentações de corrente inferiores ou iguais à 32A, o circuito elétrico correspondente deve ser protegido por um dispositivo à corrente diferencial residual inferior ou iguais à 30mA.
- (RUS) В любом помещении, где установлена ванна или есть душевое пространство, а также розетки с напряжением меньше или равным 32A, электрическая цепь должна замыкаться через УЗО (ток отсечки не более 30 mA).

01

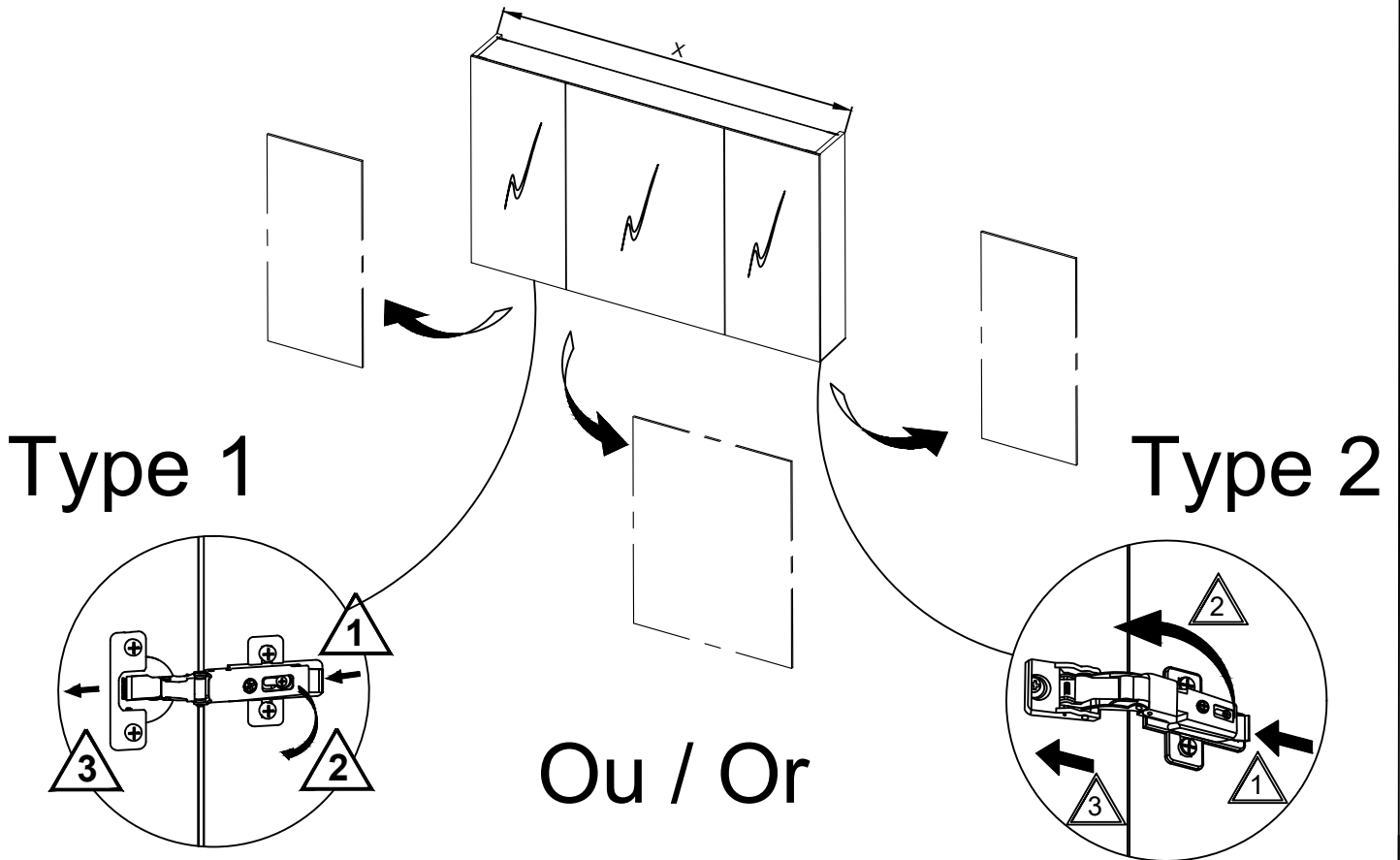

02

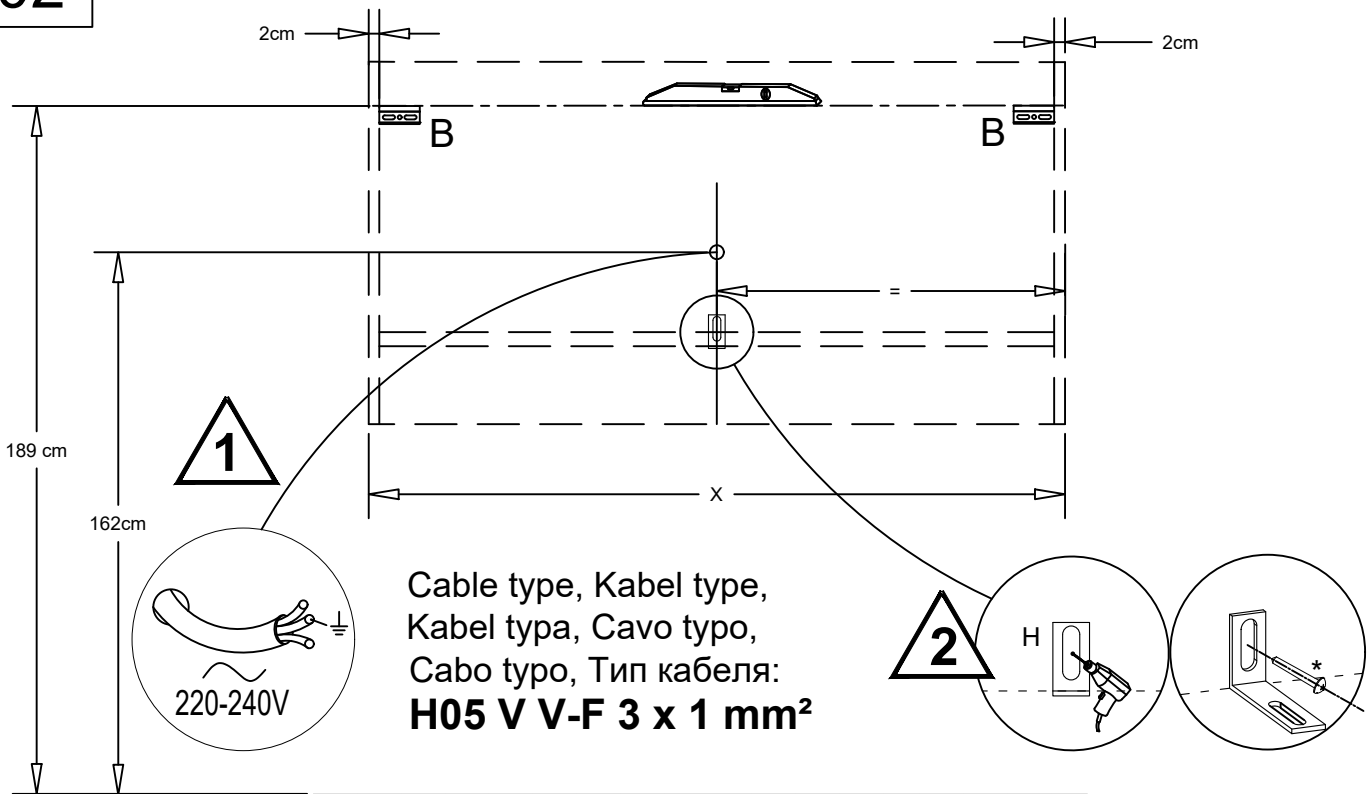

03

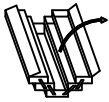
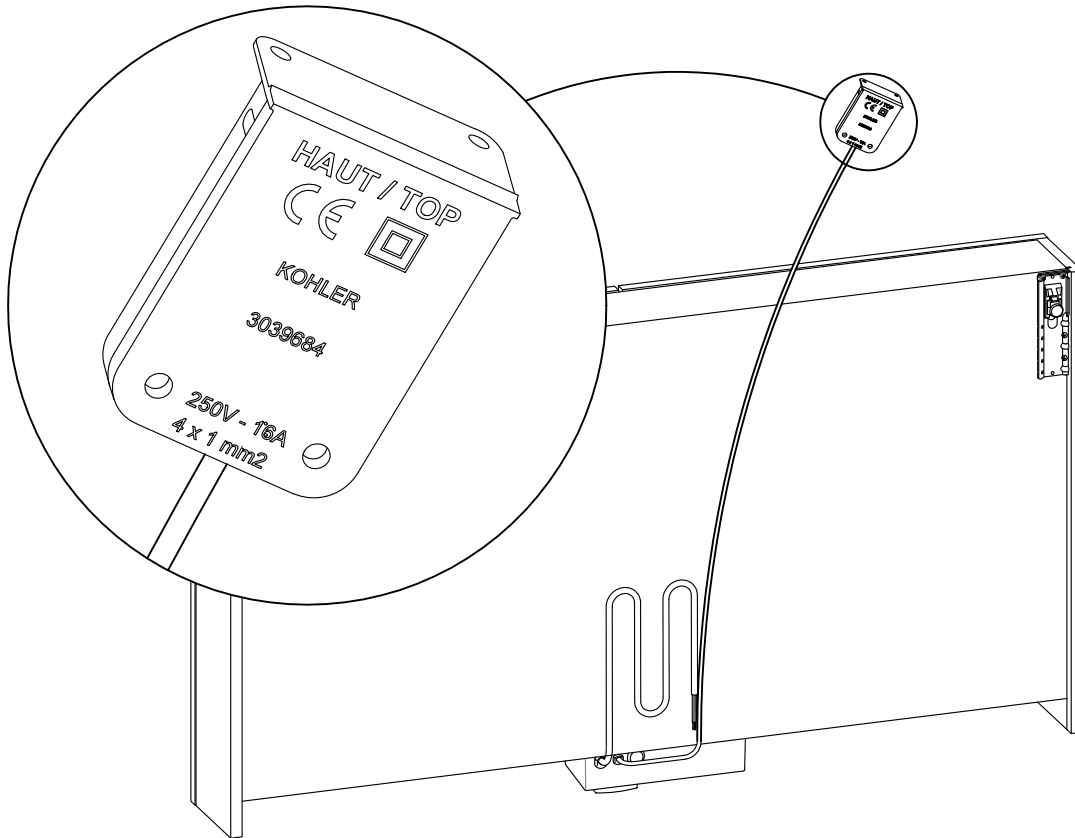

04

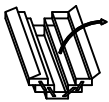
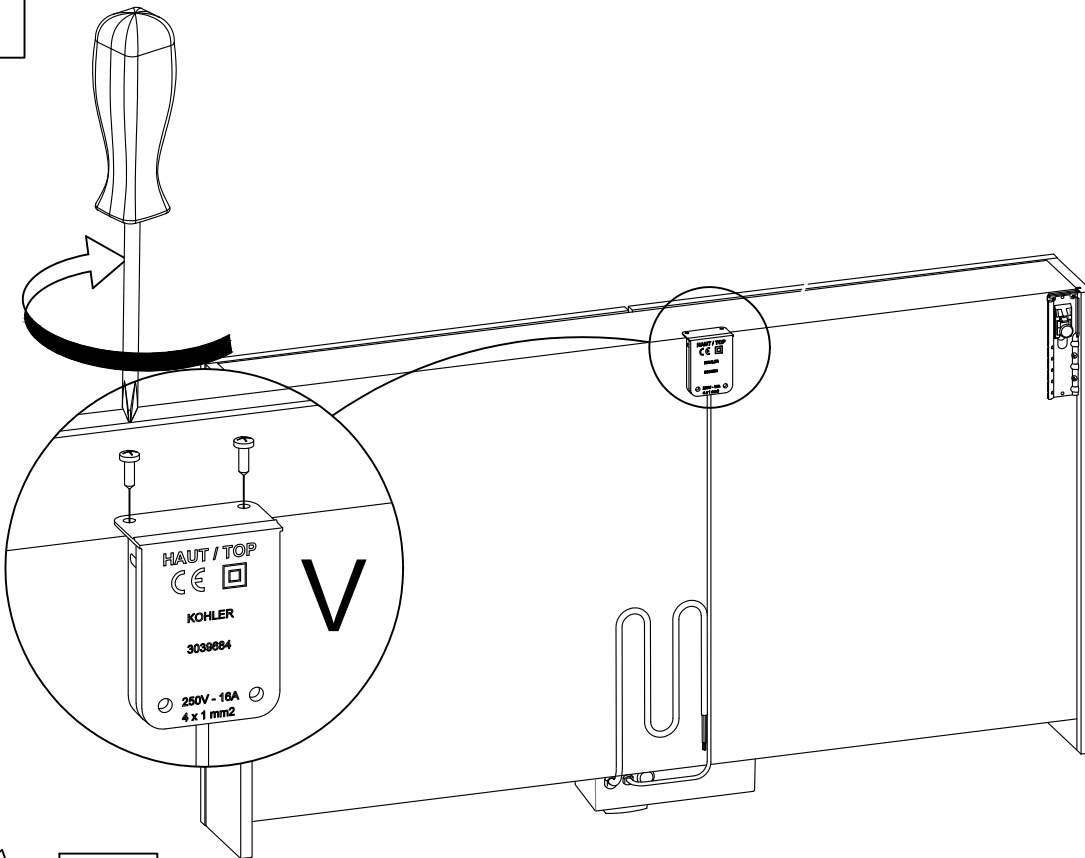

05

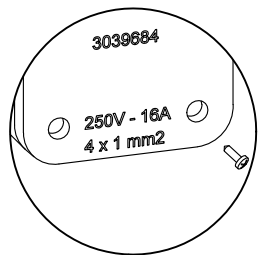

1

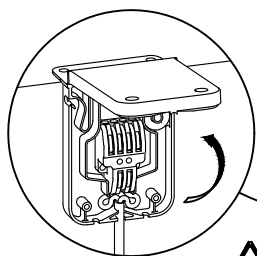

2

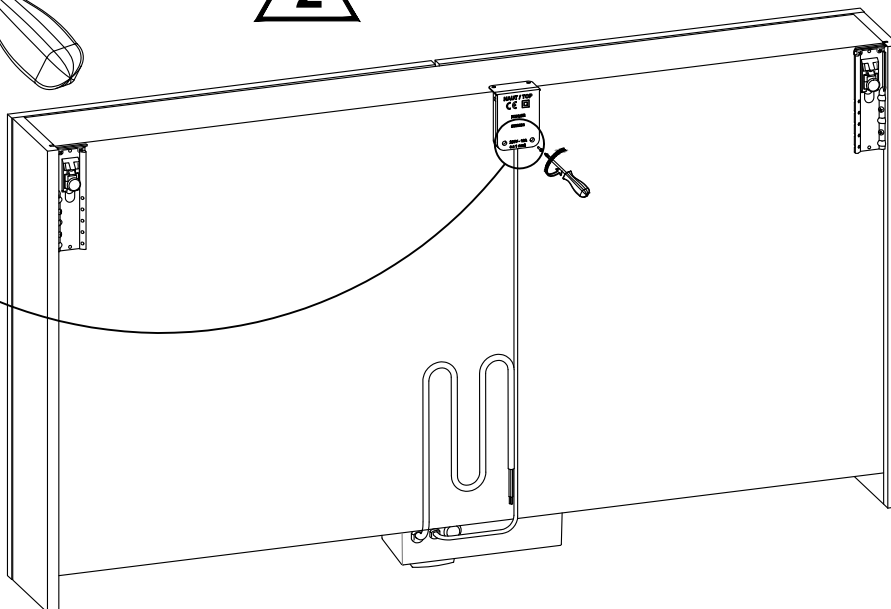
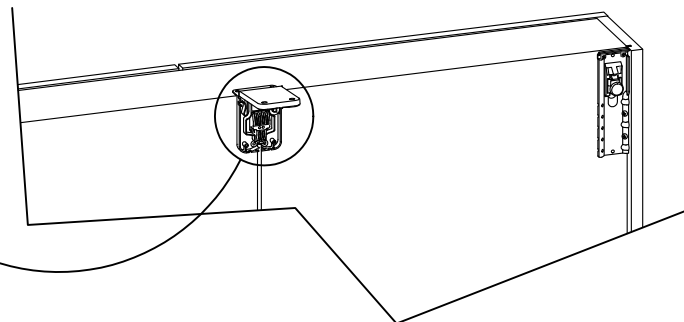

06

- (F) Le type de câble des luminaires pouvant être raccordé au boîtier devra être du type H03VVH2-F
- (GB) The type of luminaire wire that can be connected to the connecting box must be H03VVH2-F type.

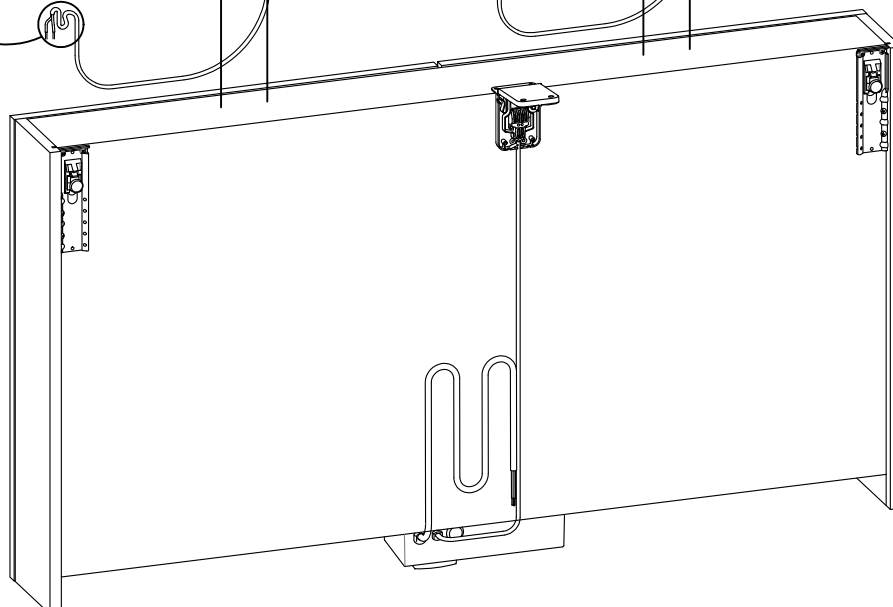
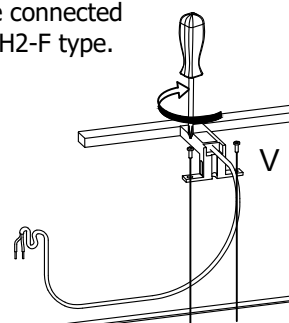
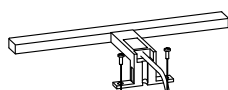
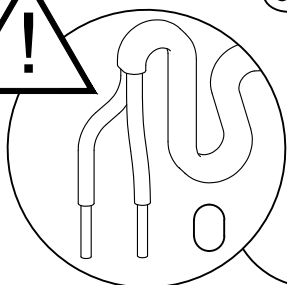

07

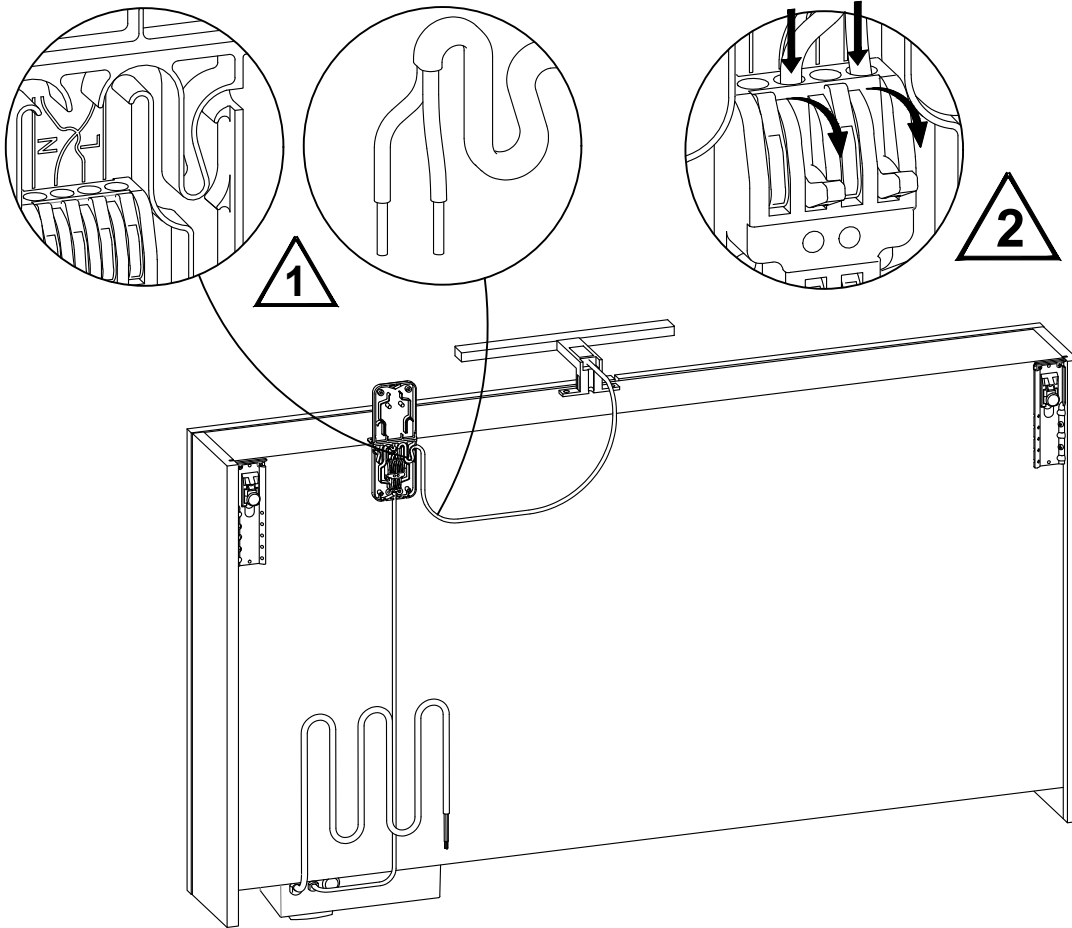

08

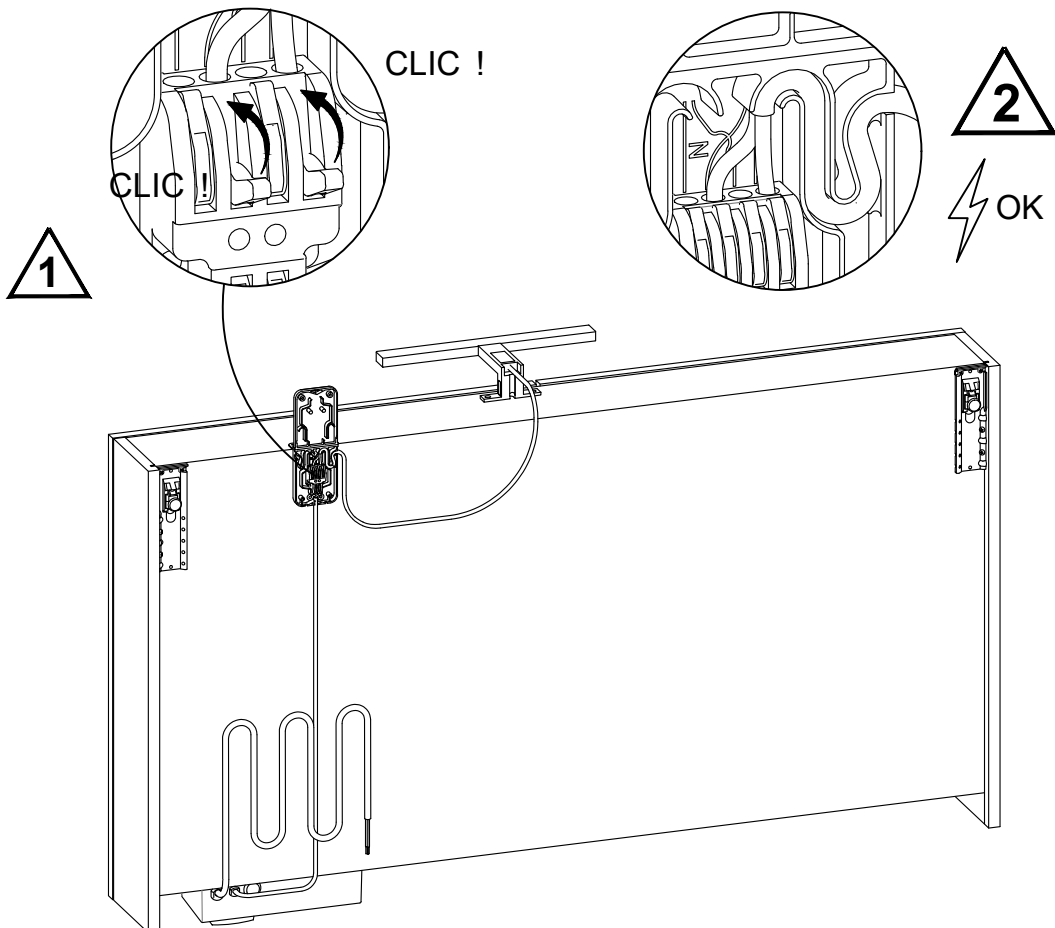

09

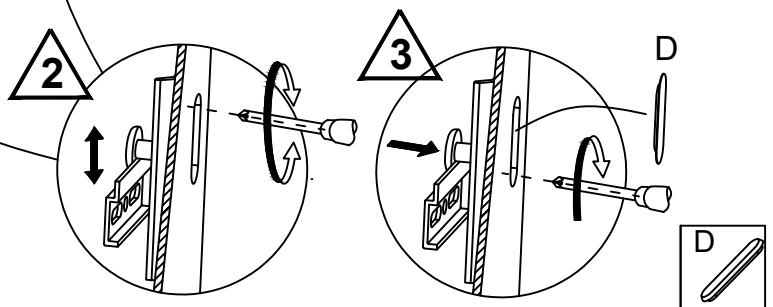
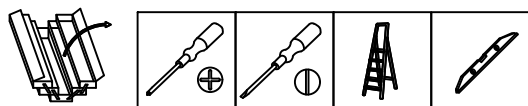
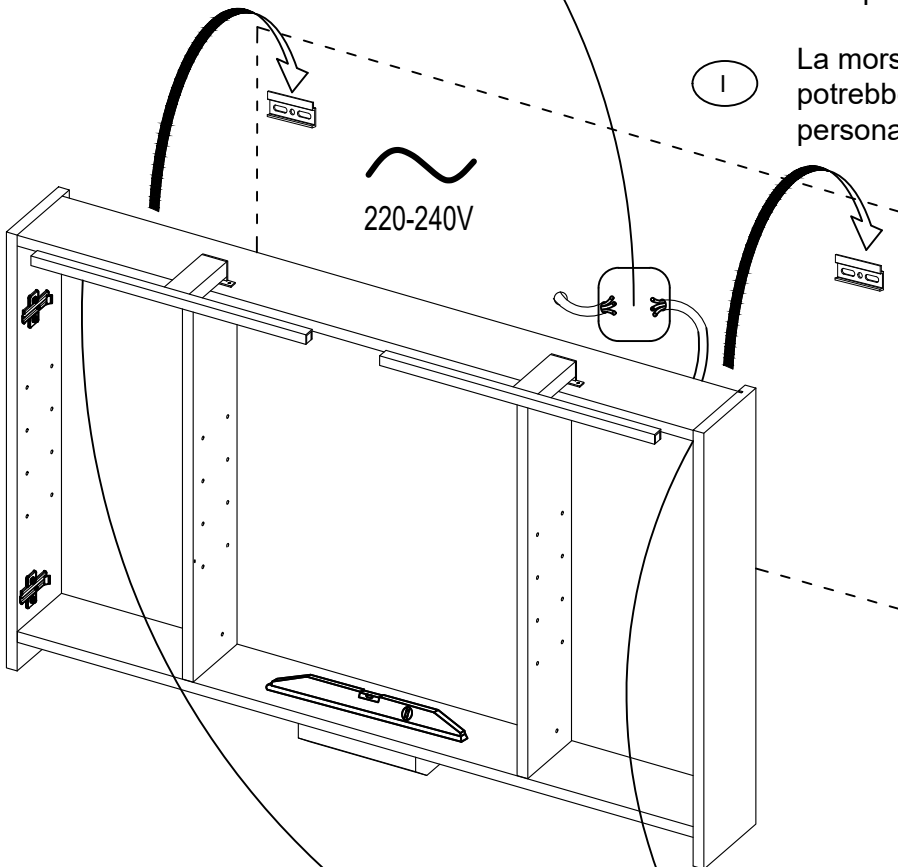
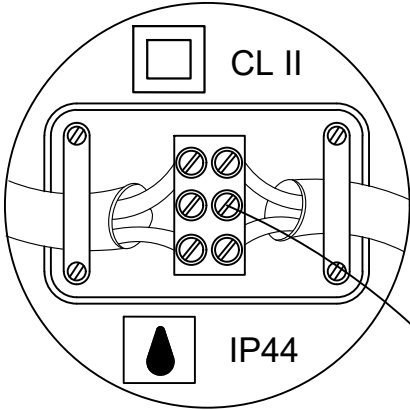
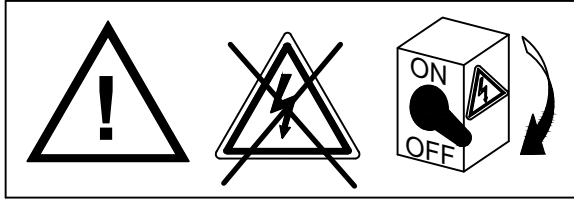

- (F) Le bloc de jonction n'est pas inclus. L'installation peut exiger l'avis d'une personne qualifiée.
- (GB) The terminal block is not included. Advice from a qualified person may be required.
- (D) Die Klemmenleiste ist nicht enthalten; Für die Installation kann der Rat einer qualifizierten Person erforderlich sein.
- (NL) Het jontieblok is niet inbegrepen, voor de installatie kan het advies van een gekwalificeerde persoon nodig zijn
- (SP) El bloque de terminales no está incluido; la instalación puede requerir el asesoramiento de una persona cualificada.
- (P) O bloco de junção não está incluído, a instalação pode exigir aconselhamento de uma pessoa qualificada
- (I) La morsettiera non è inclusa ; l'installazione potrebbe richiedere la consulenza di una persona qualificata

Cable type, Kabel type, Kabel typa, Cavo typo, Cabo tyro, Тип кабеля:  
**H05 V V-F 3 x 1 mm<sup>2</sup>**

10

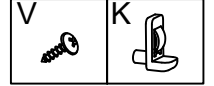
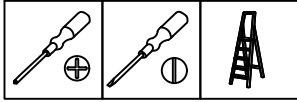
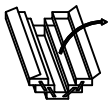
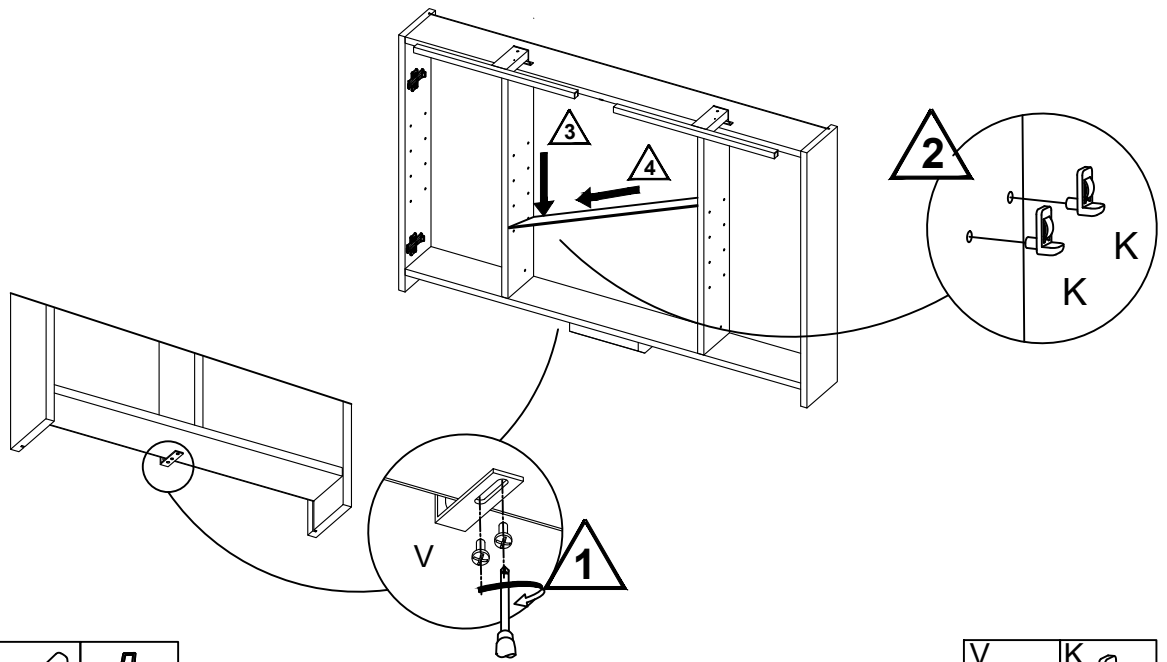

11

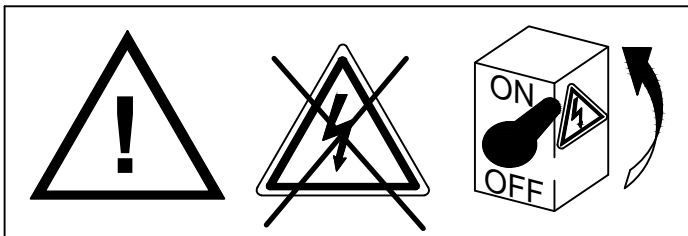
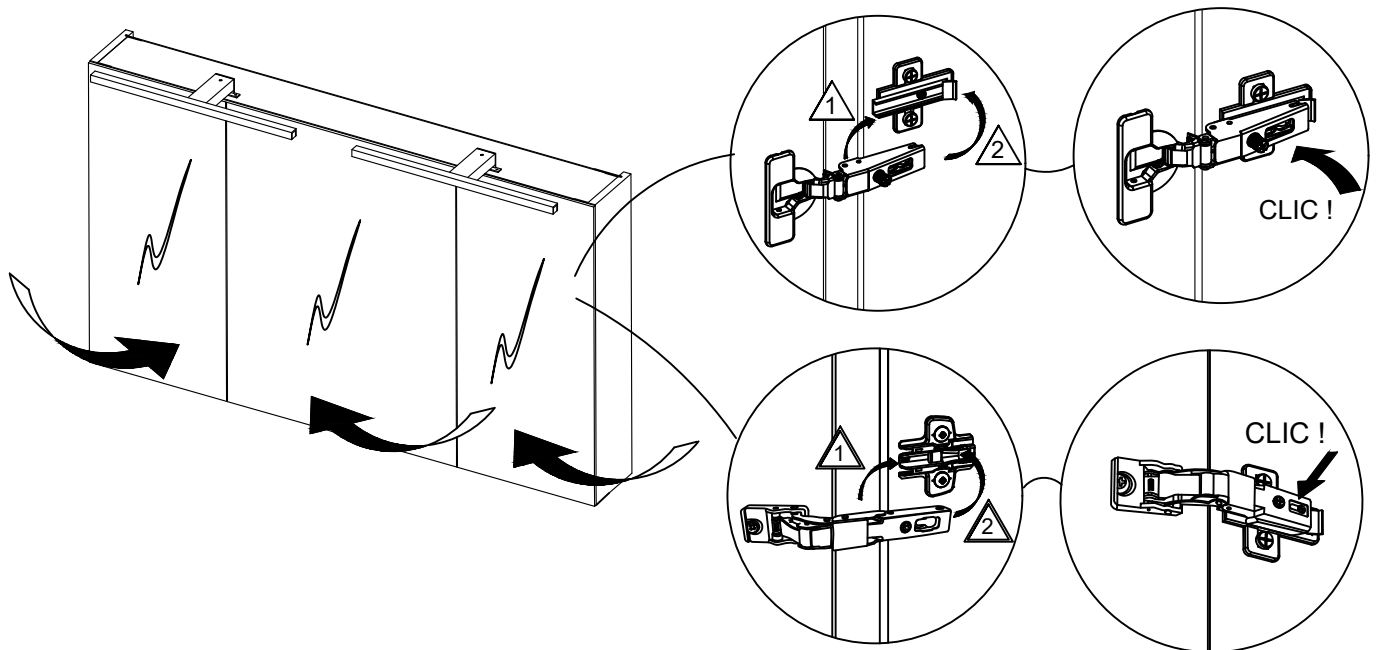



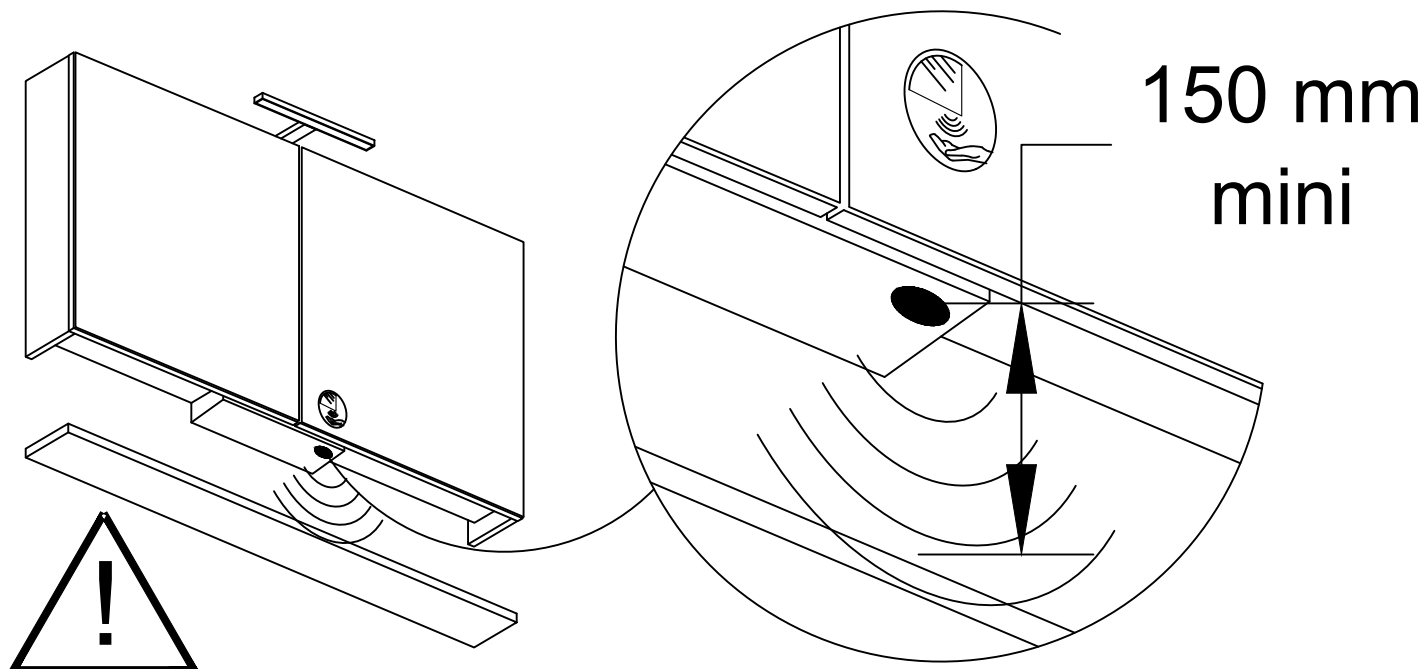

(F)

Une distance libre de 150 mm minimum doit être respectée entre le sensor et un obstacle pouvant interférer avec le faisceau et créer un dysfonctionnement.

(GB)

A clearance area of 150 mm minimum should be respected between sensor and any other equipment that could interfere with the sensor beam and thus create a malfunction.

(D)

Um korrekt zu funktionieren muss unter dem Sensor eine Leere von mindestens 150 mm vorhanden sein. Ein Hindernis oder ein Gerät, das sich weniger als 150 mm unter dem Sensor befindet, kann mit dem Strahl interferieren und zu einer Fehlfunktion des Sensors führen.

(NL)

Een vrije afstand van 150 mm tussen de sensor en een obstakel (of een toebehoren) moet gerespecteerd worden om een storing van de sensorstraal te vermijden.

(SP)

Se debe respetar una distancia mínima de 150 mm entre el sensor y un equipamiento puesto que puede interferir con el haz y provocar un mal funcionamiento.

(P)

Garantir uma distância mínima de 150 mm entre o sensor e qualquer outro equipamento que possa interferir com o feixe do sensor.

(I)

È obbligatorio rispettare una distanza libera di almeno 150 mm tra il sensore e qualsiasi altra apparecchiatura che possa interferire con il raggio del sensore e creare così un malfunzionamento.

(RUS)

В зоне действия сенсора на расстоянии 150 мм, не должно находиться никаких предметов, потому что близлежащие предметы могут отражать излучение сенсора и приводить к его неработоспособности.

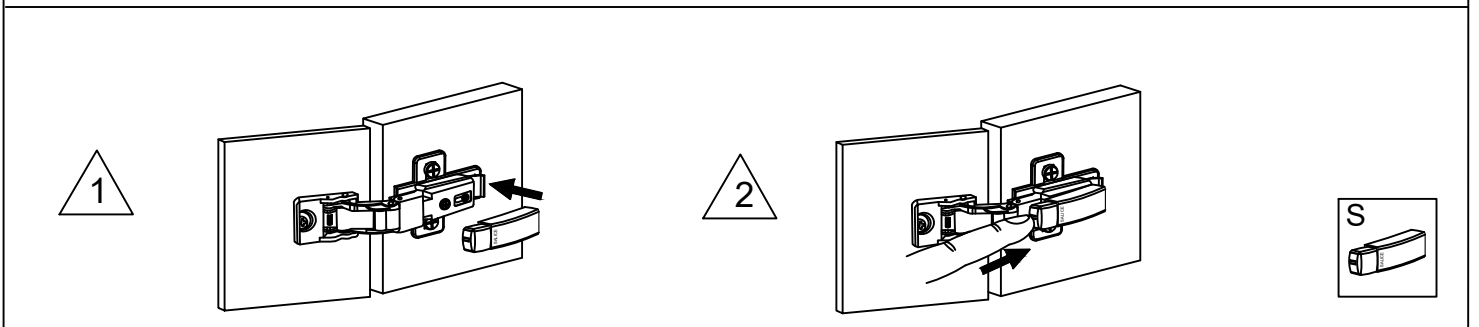
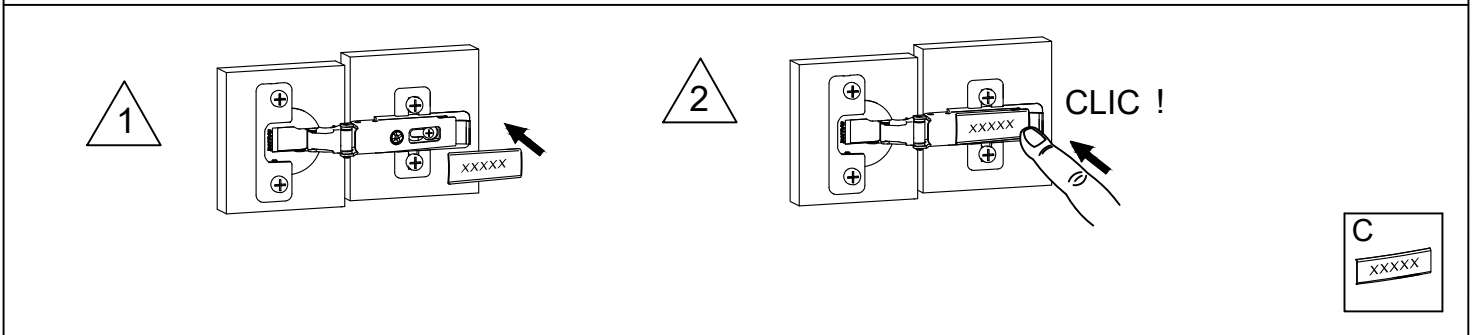
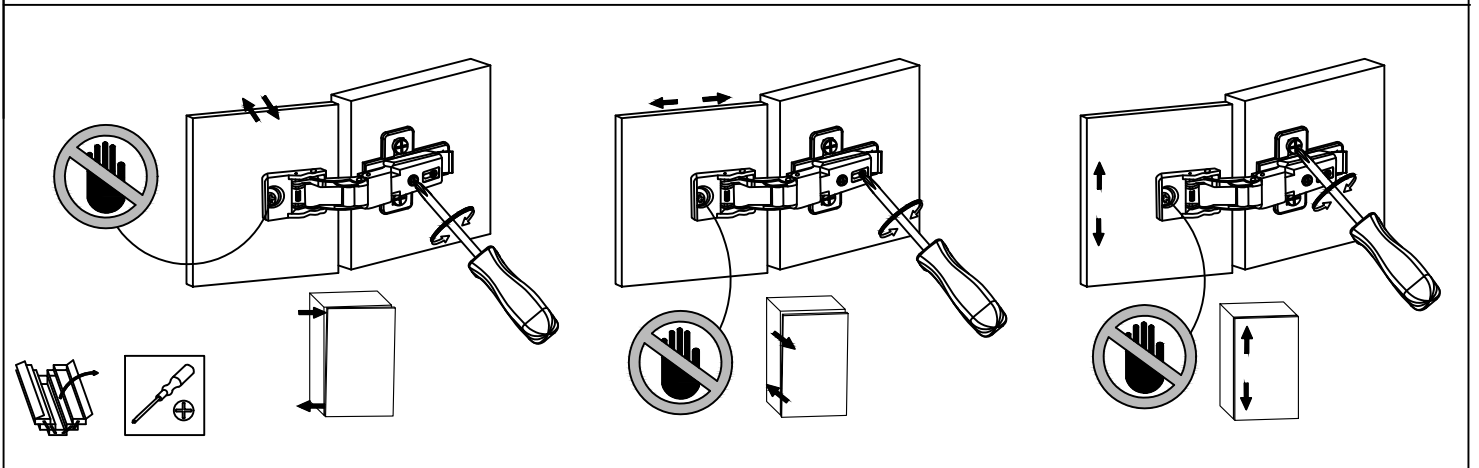
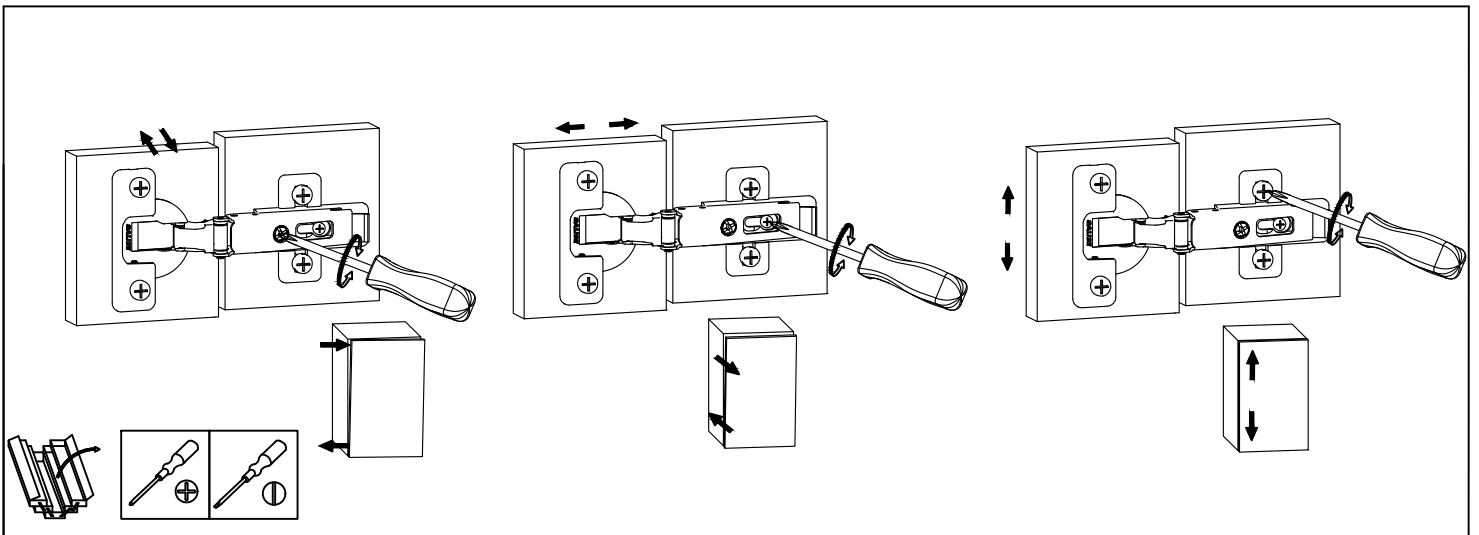

Respecter les indices de protections requis en fonction des volumes d'installation, y compris pour les luminaires destinés à être montés sur le meuble.